

FLANGE TYPE ROTARY TORQUE TRANSDUCERS

MODEL

SDN

Feature

- 비회전형 torque transducers
- Strain gauge 방식으로 정밀도가 높다.



Dimension

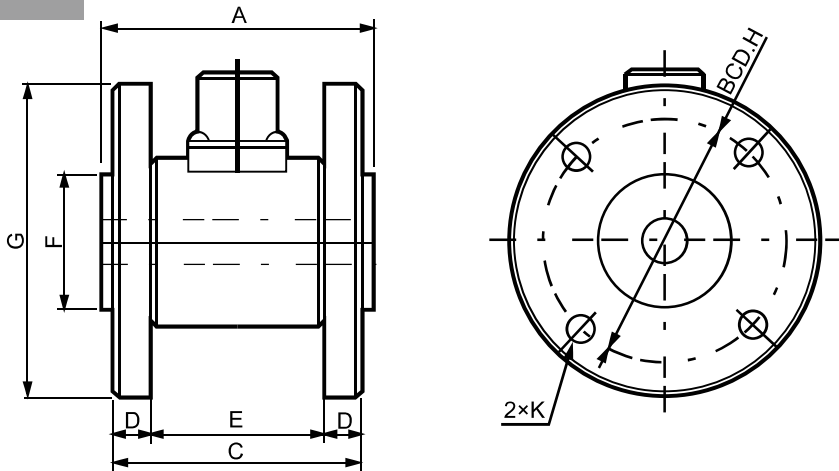

Specification

Rated capacity	2kgf.cm ~ 100kgf.m
Rated output	1.0mV/V ± 1%
Nonlinearity	0.2% of R.O
Hysteresis	0.2% of R.O
Repeatability	0.2% of R.O
Terminal resistance input	350±3.5Ω
Terminal resistance output	350±3.5Ω
Insulation resistance	2000MΩ
Temperature range compensated	0.01% R.O/10°C
Temperature range safe	0.01% Load/10°C
Excitation recommended	10V DC
Safe overload	150% R.C
Cable	ø 7 Shield 3m

Dimension table (unit : mm)

Capacity	A	C	D	E	ØF	ØG	ØH	ØK
2,3,5kgf-cm	61	57	6	45	35h7	74	60	4-6.5
10,20,50kgf-cm	61	57	6	45	40h7	79	65	4-6.5
1,2kgf-m 160	70	66	8	50	40h7	84	70	6-6.5
5,10kgf-m	80	74	12	50	50h7	94	75	4-9
20kgf-m	86	80	15	50	50h7	98	78	4-11
50kgf-m	126	120	20	80	60h7	118	95	6-11
100kgf-m	136	130	20	90	70h7	125	100	6-13